

**SERIES 31H
ES-0229**

Date: March 1994

ATTENTION

THIS DOCUMENT IS VALID IF AND ONLY IF YOU PERSONALLY DOWNLOADED IF FROM WWW.BRAY.COM
IF YOU RECEIVED THIS DOCUMENT FROM ANY OTHER SOURCE, PLEASE TAKE INTO CONSIDERATION THAT ALTERATIONS
COULD HAVE BEEN MADE, FOR AN ORIGINAL COPY, PLEASE CONTACT BRAY VALVE AT 281-894-5454

Valve Size	A	B	C	D	E	F	Top BC	Plate No. of Holes	Drilling Hole Diameter	G	H	J	K	L	Lug BC	Bolting No. of Holes	Data Threads UNC-2B	Adapter Code	Weight
2	3.69	1.62	2.00	2.84	5.50	3.54	2.76	4	.39	.55	.39	1.25	1.32	2.30	4.75	4	.62-11	A	7.0
2½	4.19	1.75	2.50	3.34	6.00	3.54	2.76	4	.39	.55	.39	1.25	1.91	2.57	5.50	4	.62-11	A	8.0
3	4.88	1.75	3.00	4.03	6.25	3.54	2.76	4	.39	.55	.39	1.25	2.55	2.81	6.00	4	.62-11	A	9.0
4	6.06	2.00	4.00	5.16	7.00	3.54	2.76	4	.39	.63	.43	1.25	3.57	4.09	7.50	8	.62-11	B	15.0
5	7.12	2.12	5.00	6.16	7.50	3.54	2.76	4	.39	.75	.51	1.25	4.63	4.61	8.50	8	.75-10	C	20.0
6	8.12	2.12	5.75	7.02	8.00	3.54	2.76	4	.39	.75	.51	1.25	5.45	5.06	9.50	8	.75-10	C	23.0
8	10.50	2.50	7.75	9.47	9.50	5.91	4.92	4	.57	.87	.63	1.25	7.45	6.05	11.75	8	.75-10	D	42.0
10	12.75	2.50	9.75	11.47	10.75	5.91	4.92	4	.57	1.18	.87	2.00	9.53	7.69	14.25	12	.88-9	E	66.0
12	14.88	3.00	11.75	13.47	12.25	5.91	4.92	4	.57	1.18	.87	2.00	11.47	9.02	17.00	12	.88-9	E	88.0

Note: K dim is disc chordal dimension at valve face.

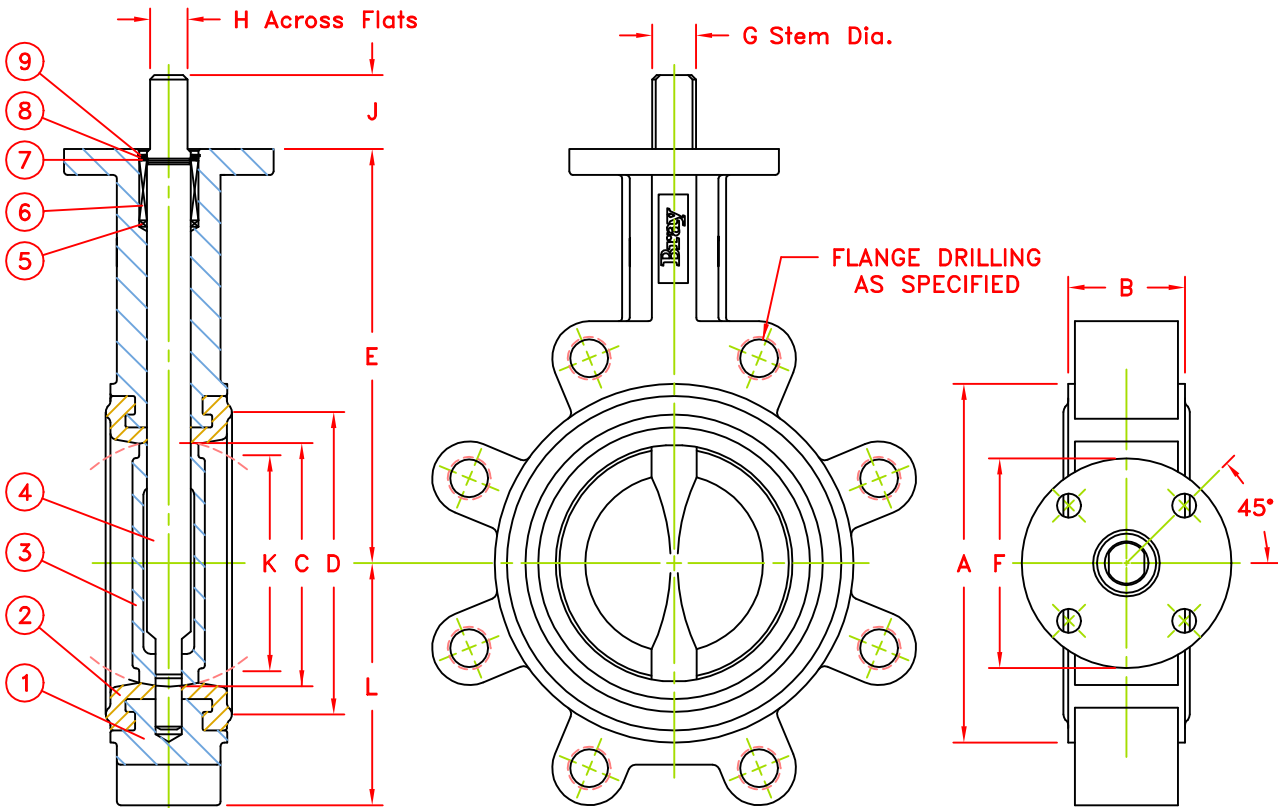

9	RETAINING RING	1			
8	THRUST WASHER	1			
7	STEM RETAINER	2			
6	BUSHING	1			
5	PACKING	1			
4	STEM	1			
3	DISC	1			
2	SEAT	1			
1	BODY	1			

ITEM No.	NAME	No. REQUIRED	SERIES/PART No.	MATERIAL	SPECIFICATION/REMARKS
----------	------	--------------	-----------------	----------	-----------------------

Valve Size _____ Flg. Drilling _____
 Pressure Rating _____
 Customer/Project _____
 Inq./P.O. No. _____
 Bray Order No. _____
 Certified Correct By _____ Date _____



The High Performance Company

BRAY VALVE & CONTROLS

A Subsidiary of BRAY INTERNATIONAL, Inc.

PARTS LIST AND DIMENSIONS (Inches)
 BUTTERFLY VALVE, SERIES 31H SIZES 2"-12"
 WITH BONDED SEAT, 250 p.s.i. (16 Bar)

Series	Size	Part No.	Material Trim Code	Drawing No.
				ES-0229

