

\*\*Note:with torque switch A=435

Unit:mm

Dimension	A	B	C	D	E	F	G	H	I	J	K	L	M	N	P	Flange Type
Model NO.														Max		
S74-0890~1330	347	227	336	∅217	406	∅295	60	∅180	235	101	1/2 PS	∅125	10	∅35	M12*1.75	F12
S74-0890~1330	347	227	336	∅217	406	∅295	60	∅180	235	101	1/2 PS	∅140	10	∅35	M16*2.0	F14

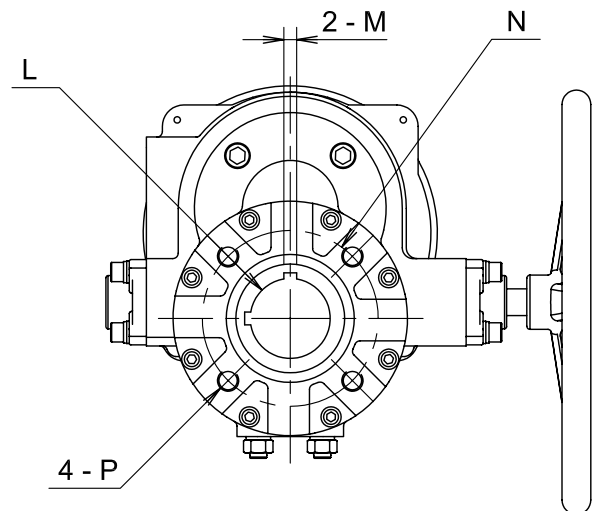
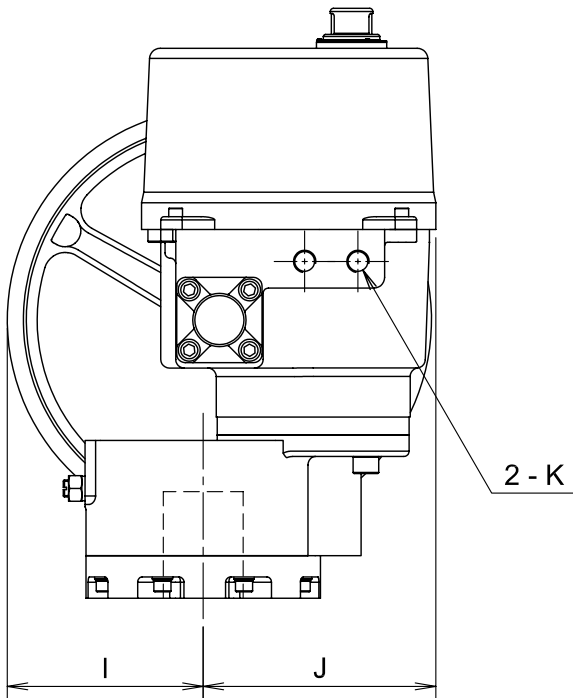
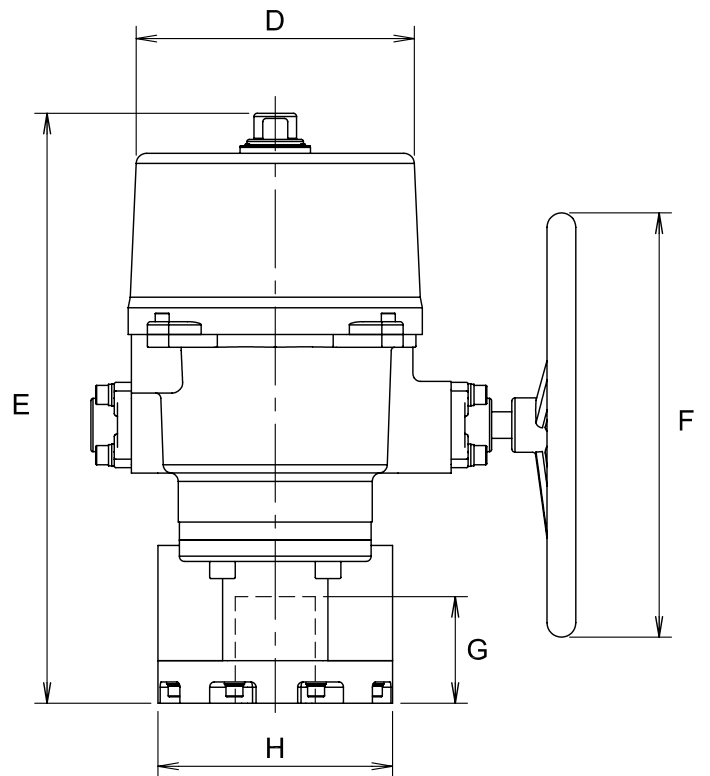
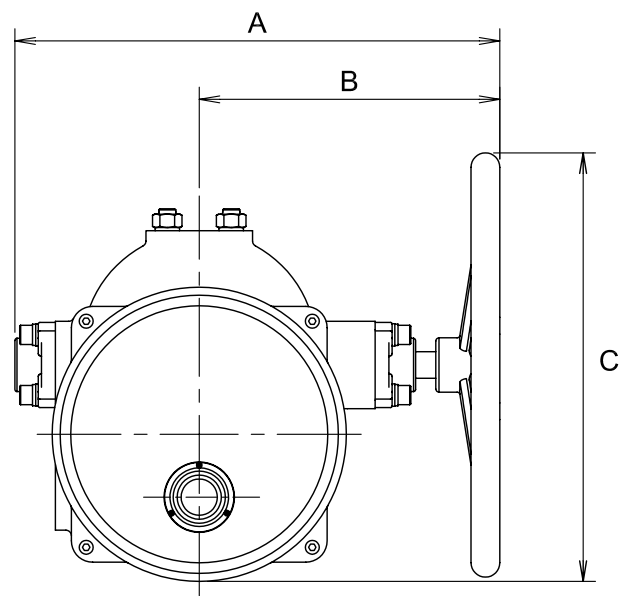

Unit:mm

Dimension	A	B	C	D	E	F	G	H	I	J	K	L	M	N	P	Flange Type
Model NO.																
S74-1770~3100	455	282	402	∅261	554	∅398	100	∅220	184	218	1/2 PS	∅75	12	∅165	M20*2.5	F16